

**AYLESBURY**

# **K VALVE**

## **INSTALLATION GUIDE**

**FOR VALVE SIZES (DN):**

**3/4" (20)**

**1" (25)**

**1 1/4" (32)**

**1 1/2" (40) HF**

**2" (50) SF**

### **IMPORTANT**

**PLEASE KEEP FOR FUTURE REFERENCE.**

**PLEASE READ THESE INSTRUCTIONS CAREFULLY AND REFER TO ANY DIAGRAMS BEFORE INSTALLATION.**

These instructions contain important information which will help you install your **KERAFLO** delayed action float valve correctly and ensure safe use and maintenance.

For further assistance please ring our Customer Helpline: **0118 921 9920**

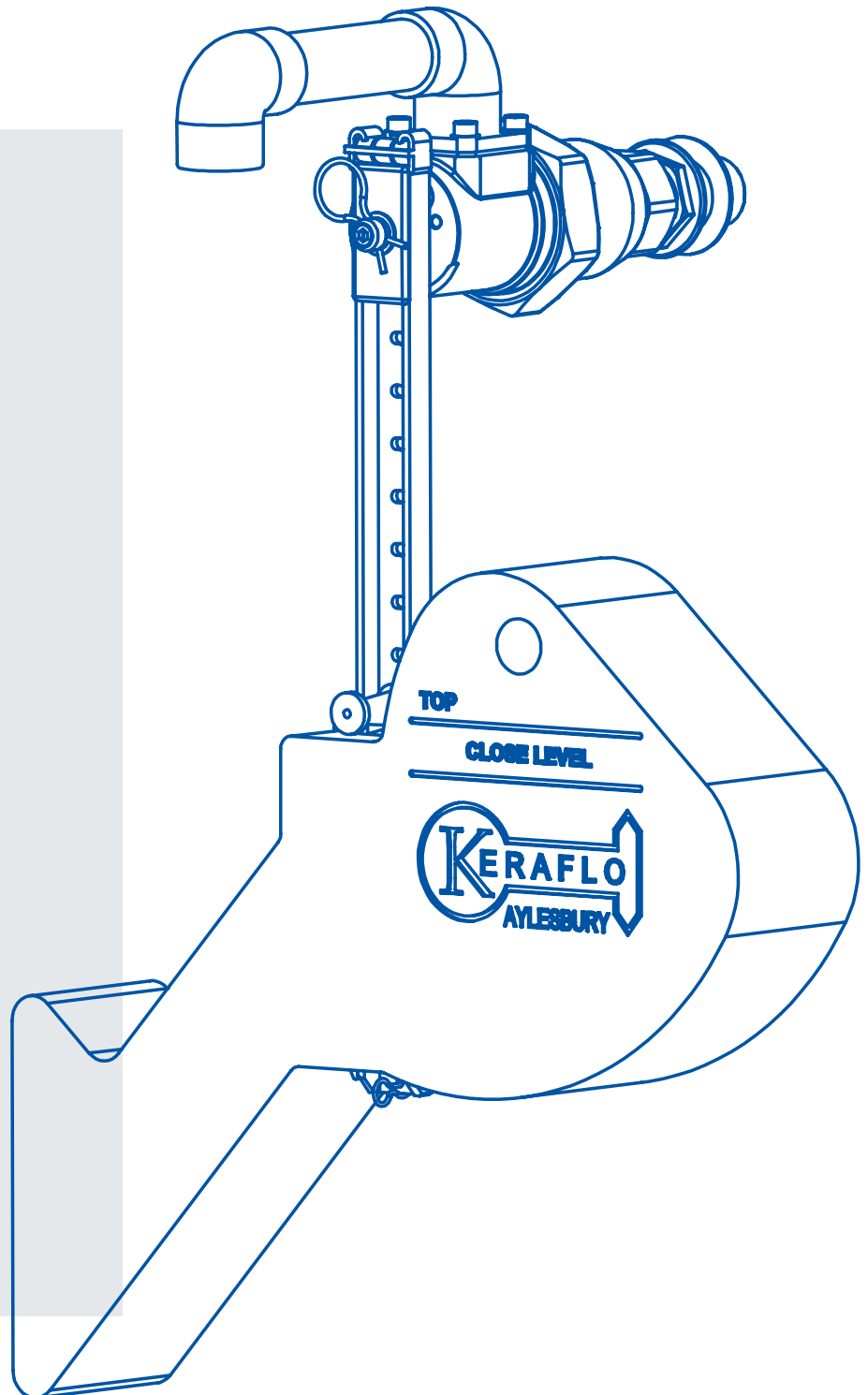



# PRE-INSTALLATION CHECKS

## RAISED VALVE CHAMBERS:

Do not use a K Type valve with a raised valve chamber.  
Use a KAX or KB Type valve for these tanks.

## OPERATING SPACE:

Check for sufficient clearance. The working dimensions are shown on the attached drawings.

## OVERFLOW/WARNING PIPES:

Check the position of the overflow and warning pipe (where fitted).  
See dimension 'R max', drawing on page 7.

## TURBULENT WATER:

Exceptionally turbulent waters, such as in cooling towers, should be avoided directly beneath the float. Calming measures such as baffle plates, still ponds etc. should be used in these installations.

## FLANGED TANKS:

The design of the valves allows sufficient clearance between the float and most internal tank flanges and ribs (Dimension G on page 8). The valve backnuts may be adjusted to enable fitting to tanks with large flanges, provided a minimum of 20mm exists between the float and tank wall throughout the arc of the float.

## ROUND TANKS:

Minimum tank diameters required.

VALVE	¾"	1"	1¼"	1½"HF	2"SF
MIN TANK DIAMETER (M)	0.95M	0.95M	1.30M	2.30M	2.30M

## SLOPING TANK WALL:

The wall to which the Aylesbury K Valve is to be attached must be vertical. If the wall around the fixing hole is sloped, tapered washers must be used. These should be available from the tank supplier.

## PIPEWORK SUPPORT:

**KERAFLO** Aylesbury valves create virtually no tank wall stress. It is therefore not necessary to provide additional support to the pipework as long as the Code of Practice for the Support of Pipework in general is met.

## ISOLATING VALVE:

An isolating valve must be fitted as near as is reasonably practicable to the **KERAFLO** valve.

# INSTALLATION INSTRUCTIONS

The valve is supplied with the float arm and discharge assemblies detached. To avoid damage it is recommended, where possible, to fit both of these assemblies **AFTER** installing the valve in the tank.

- 1 Before fitting the valve, flush the supply pipes to clear all debris.
- 2 Remove and retain the double-R clip.
- 3 Remove and discard the red protective cap from the tail.
- 4 Remove and retain one backnut.
- 5 Insert the valve tail through the hole in the tank wall, replace the backnut with the flanged side against the tank wall.
- 6 Connect the supply pipe, after an isolating valve, then hand tighten backnut to hold the valve in place. To prevent the valve turning when tightening the pipe fitting, use either a wrench or a spanner on the valve tail where indicated in diagram 2.

**DO NOT USE A WRENCH ON ANY OTHER PART OF THE VALVE.**

## WARNING!

THE BUILT-IN SPIRIT LEVEL MUST BE USED TO ALIGN THIS VALVE. FAILURE TO FOLLOW THE PROCEDURE LISTED BELOW WILL PREVENT THE VALVE OPERATING CORRECTLY.

INSTALLATION OF VALVES SHOULD BE IN ACCORDANCE WITH THE WATER SUPPLY (WATER FITTINGS) REGULATIONS 2010 AND BS 8558:2011.

TANKS AND PIPES SHOULD BE DISINFECTED USING THE PROCEDURES IN BS EN 806-4:2010 SECTION 6: COMMISSIONING.

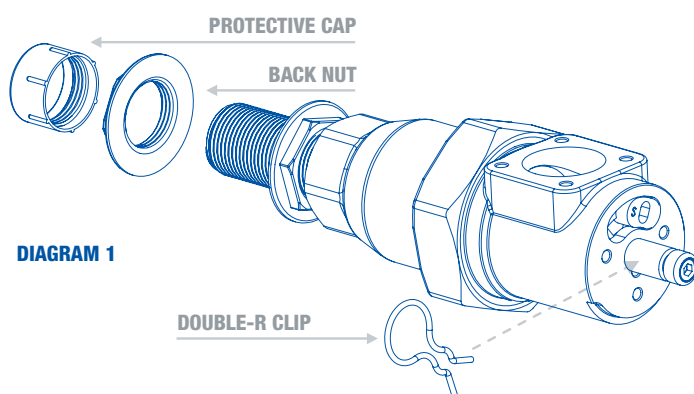

DIAGRAM 1

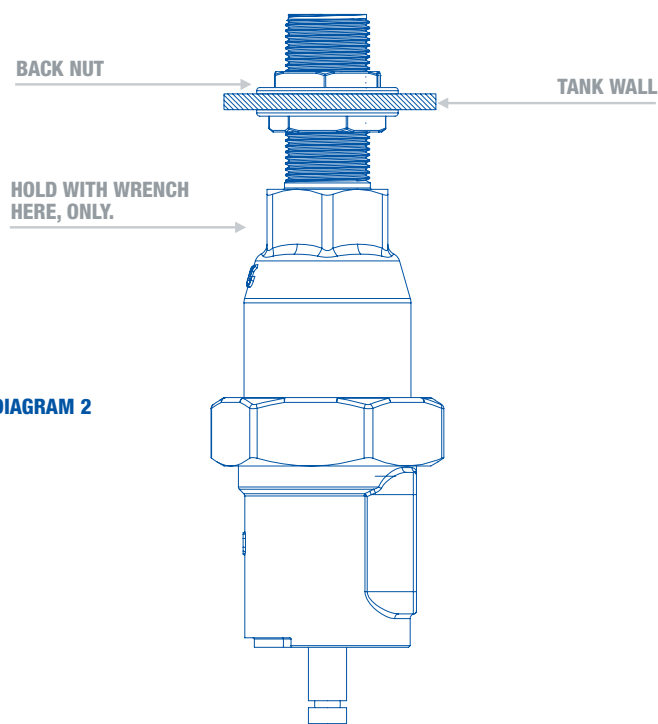

DIAGRAM 2

- 7 Fit the float arm assembly ensuring the pin locates in the actuator.
- 8 Refit the double-R clip, retained at step 2, to hold the float arm assembly in place.
- 9 Rotate the valve as necessary so the float arm is **VERTICAL** and the valve is in the open position. Use the integrated spirit level, ensuring that the bubble is between the black lines, to check that the valve is aligned horizontally (Diagram 4).
- 10 Tighten backnuts then **CHECK ALIGNMENT AGAIN**, as in step 9.
- 11 Using the 4mm Allen key supplied, fit the discharge assembly referring to Diagram 5 for the direction.
- 12 Remove and discard the protective cap from the discharge assembly, before adjusting closing level, testing and use.

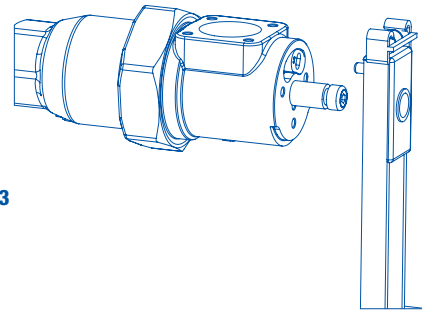

DIAGRAM 3

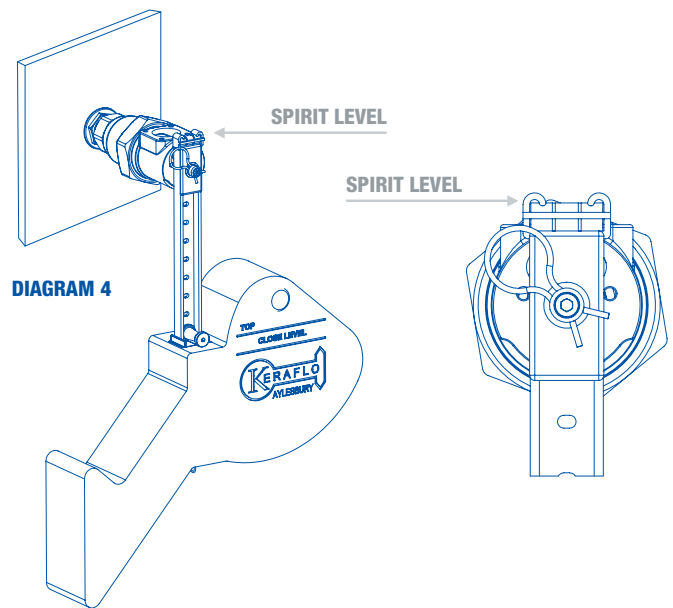

DIAGRAM 4

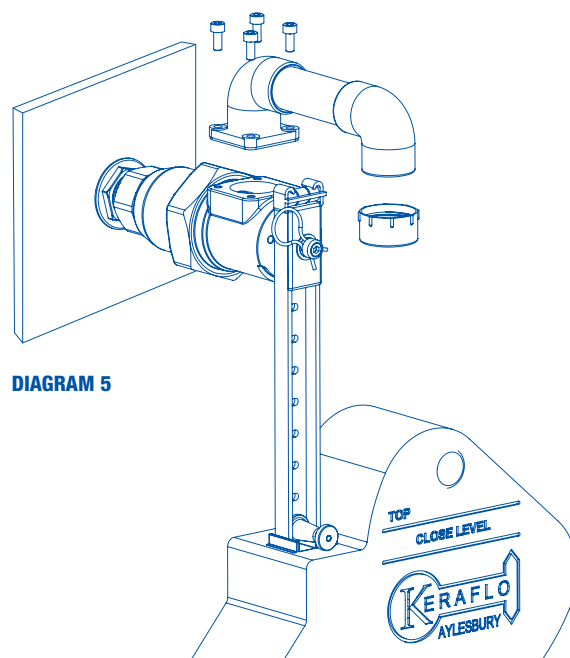

DIAGRAM 5

**ALIGNMENT WARNING!**

**THE VALVE MUST BE FITTED WITH THE SPIRIT LEVEL ALIGNED WHEN THE VALVE IS FULLY OPEN. THIS IS CRITICAL TO THE OPERATION OF THE VALVE.**

## ADJUSTING CLOSING WATER LEVEL (TWL)

- 1 Pull out the float adjusting catch.
- 2 Slide the float along the arm to the desired position.
- 3 Release the catch and ensure pin locates in desired hole.

## TESTING

Before leaving the installation, manually move the valve to test its operation a number of times, ensuring that it moves freely from the open to the closed position and from the closed to the open position.

Where a valve has not been in operation for one month it is also recommended that the above procedure is carried out.

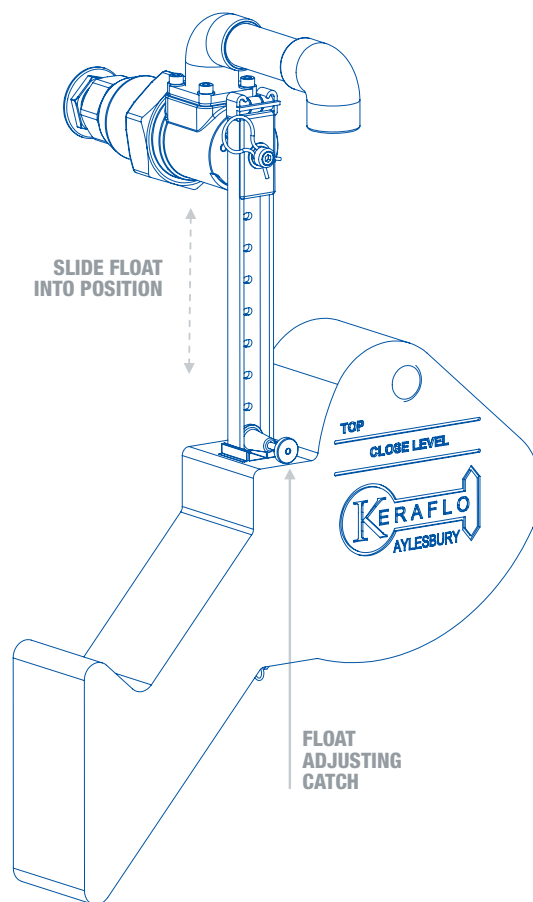
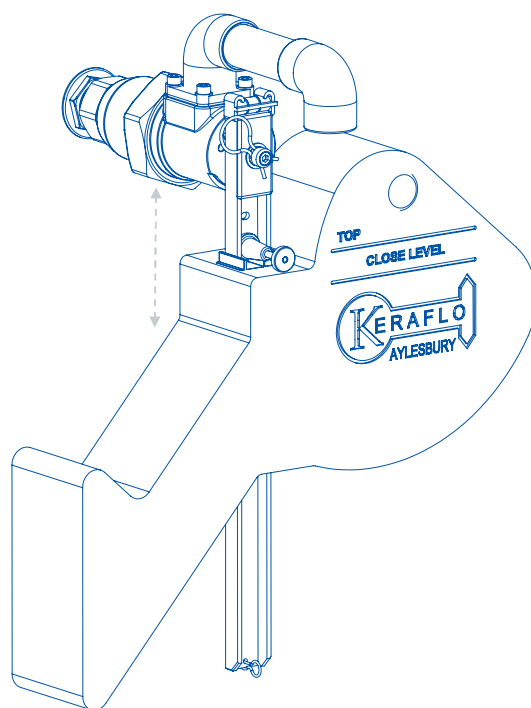

DIAGRAM 6



# SIZES (DN):

3/4"(20)      1 1/4"(32)      2"(50)SF  
 1"(25)      1 1/2"(40)HF

## WARNING

THE FLOAT ARM MUST BE FITTED ABSOLUTELY VERTICALLY (IN THE OPEN POSITION) AS INDICATED BY THE SPIRIT LEVEL (SEE BELOW).

MISALIGNMENT WILL PREVENT THE VALVE FROM CLOSING.

ENSURE OVERFLOWING LEVEL IS NOT LOWER THAN THAT SHOWN BELOW (RMAX); AND HIGHER FOR TURBULENT WATER.

LEVEL DIFFERENTIAL: 50 - 100MM NON-ADJUSTABLE DELAYED ACTION.

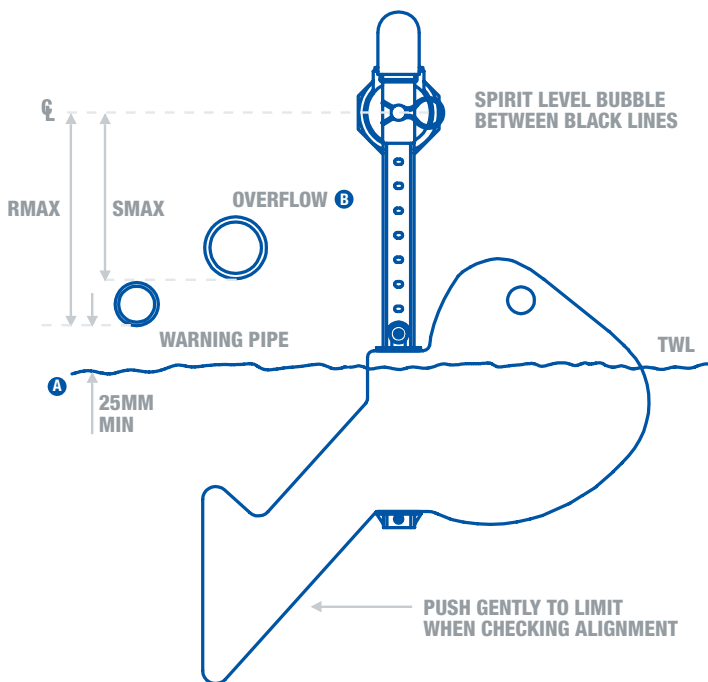

## NOTES:

**A** SCHD2, SECT 7, G16.5 Water Regs. Gaps should be more if water is turbulent – especially if near valve discharge. 40mm minimum for valves 1 1/2" (DN 40mm) or larger – recommended by **KERAFLO**.

**B** Typically twice inlet bore. SCHD 2, SECT 7, G16.10 Water Regs. Warning/overflow pipes should be capable of taking any possible flow in the pipe arising from inlet valve failure.

See page 8 for side view.

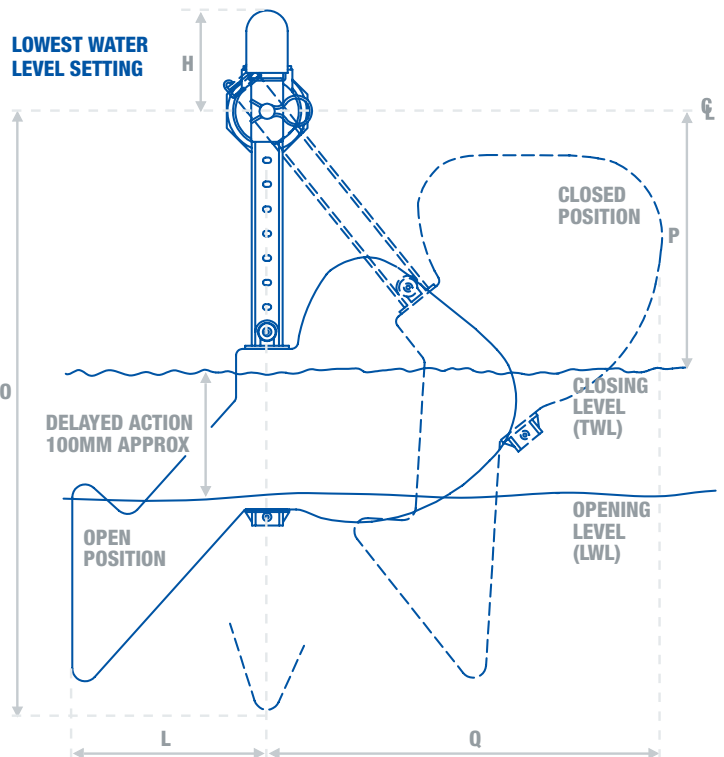
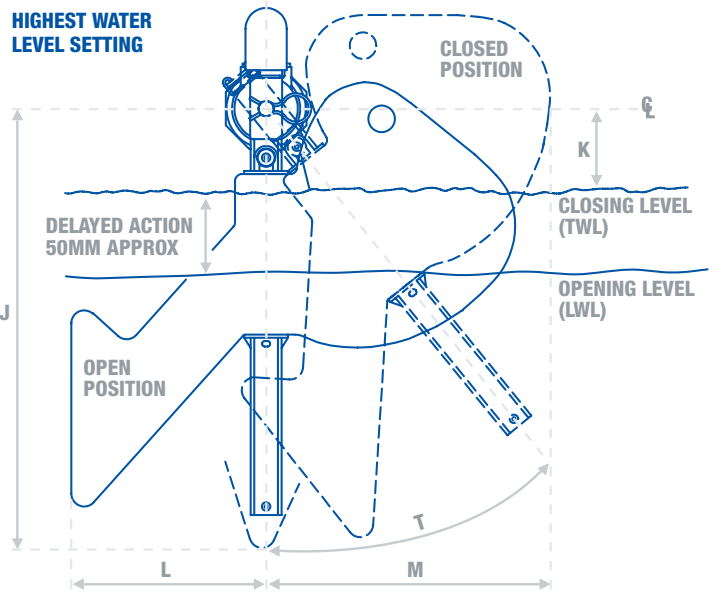

DN	20	25	32	40HF	50SF
SIZE	3/4"	1"	1 1/4"	1 1/2"HF	2"SF
H	83	83	111	111	111
J	340	340	370	390	390
K	70	70	70	80	90
L	155	155	155	155	155
M	225	225	225	270	270
N	30	30	60	25	25
O	470	470	510	510	510
P	210	210	250	250	250
Q	315	315	340	340	340
RMAX	185	185	225	225	225
SMAX	160	160	200	200	200
T	41°	41°	41°	40°	40°



# SIZES (DN):

3/4"(20)

1"(25)

1 1/4"(32)

1 1/2"(40)HF

2"(50)SF

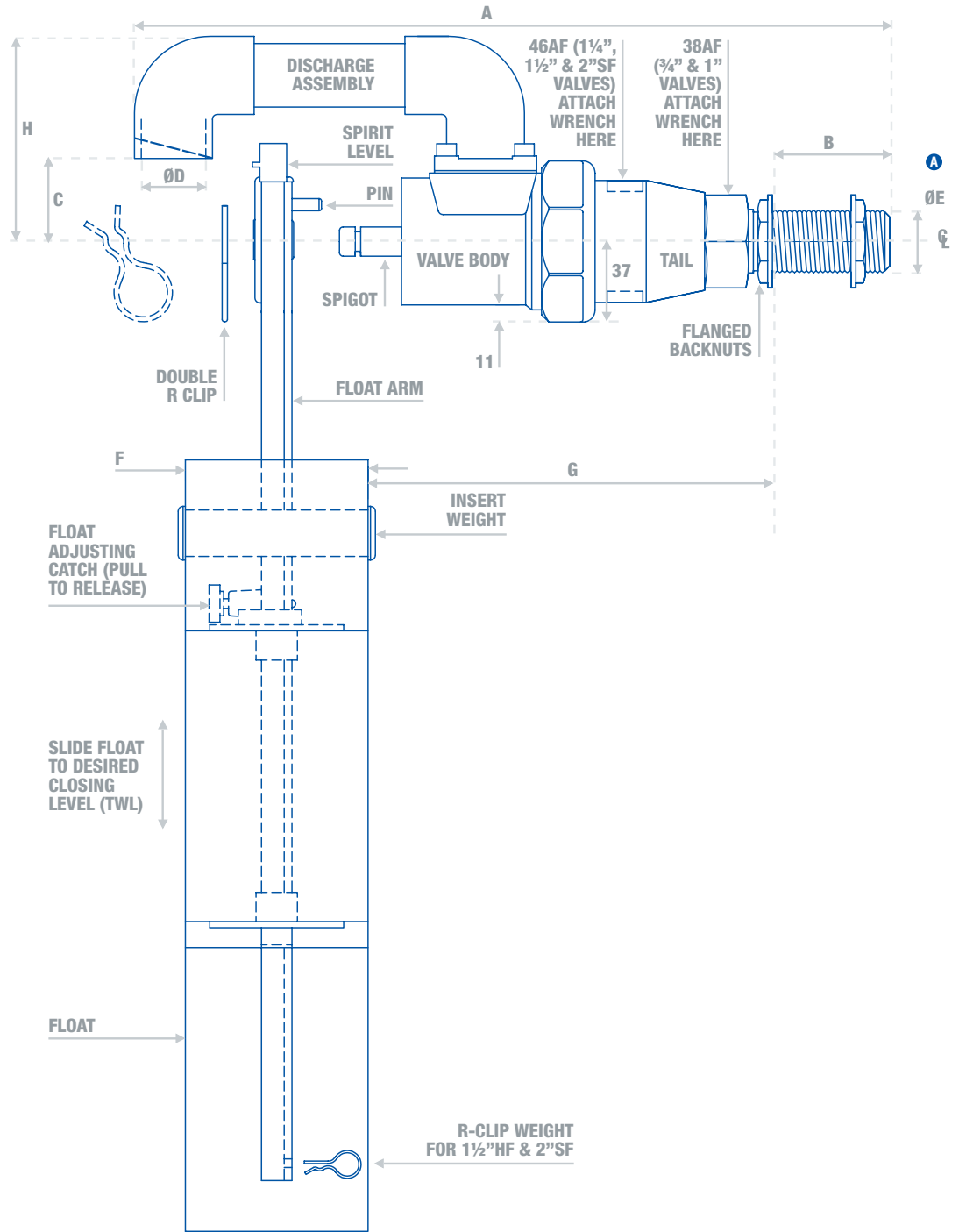

## BASIC SPECIFICATION:

Maximum static pressure: 10bar

Maximum flow rate: 3m/s nominal pipe velocity (Flow Rate and Pipe Velocity chart is available at [www.keraflo.co.uk](http://www.keraflo.co.uk))

Temperature range: 1° – 60°C

Level differential: 50 - 100mm non-adjustable delayed action, parallel male BSP (G) connection.

## NOTES

Ⓐ Suitable for spigot and fibre washer fittings on 3/4" and 1" valves

See page 7 for front view.

DN	20	25	32	40HF	50SF
<b>SIZE</b>	<b>3/4"</b>	<b>1"</b>	<b>1 1/4"</b>	<b>1 1/2" HF</b>	<b>2" SF</b>
<b>A</b>	330	330	345	390	395
<b>BMAX</b>	44	44	55	85	92
<b>C</b>	33	33	55	55	55
<b>ØD</b>	19.5	26.9	35.4	35.4	35.4
<b>ØE</b>	26.5	33	42	47.5	60
<b>F</b>	75	75	90	200	200
<b>GMIN</b>	124	124	99	59	60
<b>H</b>	83	83	111	111	111